

PGA OFFICE CENTER - A P.U.D.

BEING A PARTIAL REPLAT OF RCA CENTER DRIVE, AS SHOWN ON MACARTHUR PARCEL 5A, RECORDED IN PLAT BOOK 111, PAGES 171 THROUGH 175, AND A REPLAT OF TRACTS "A", "B", "C" AND "WMT-2A", AS SHOWN ON MACARTHUR PARCEL 5A-REPLAT, RECORDED IN PLAT BOOK 122, PAGES 156 THROUGH 160, PUBLIC RECORDS OF PALM BEACH COUNTY, FLORIDA. LYING IN SECTION 1, TOWNSHIP 42 SOUTH, RANGE 42 EAST, AND SECTION 6, TOWNSHIP 42 SOUTH, RANGE 43 EAST CITY OF PALM BEACH GARDENS, PALM BEACH COUNTY, FLORIDA

MARCH 2020 SHEET 7 OF 7

88

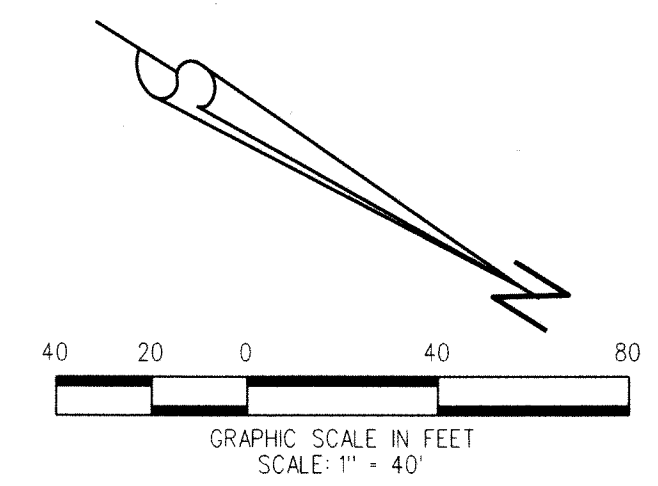

SHEET 7 OF 7

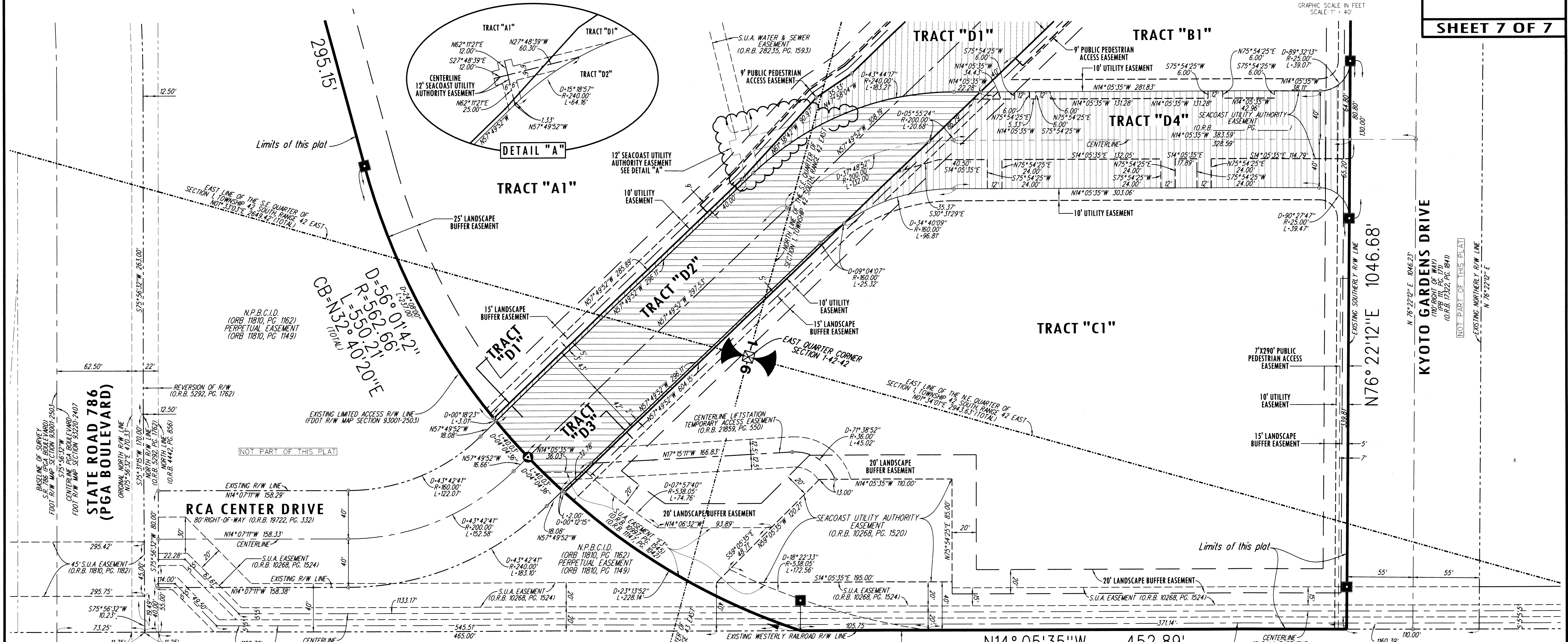

PLAT POSITION AND ORIENTATION:

- BEARINGS AND COORDINATES SHOWN HEREON ARE GRID
- LINEAR UNITS: US SURVEY FOOT
- DATUM: NORTH AMERICAN DATUM OF 1983/1990 ADJUSTMENT
- ZONE: FLORIDA EAST
- COORDINATE SYSTEM: 1983 STATE PLANE TRANSVERSE MERCATOR PROJECTION
- PROJECT SCALE FACTOR: 1.000040619
- DISTANCES SHOWN HEREON ARE GROUND DISTANCES, UNLESS OTHERWISE NOTED.
- GROUND DISTANCE X SCALE FACTOR = GRID DISTANCE

ABBREVIATIONS:

- D = CURVE'S DELTA ANGLE
- R = CURVE'S RADIUS
- L = CURVE'S ARC LENGTH
- CB = CURVE'S CHORD BEARING
- CL = CURVE'S CHORD LENGTH
- CONC. = CONCRETE
- D.E. = DELTA ANGLE
- FDOT = DRAINAGE EASEMENT
- TRANSP. = FLORIDA DEPARTMENT OF TRANSPORTATION
- FND. = FOUND
- L. = LENGTH
- MON. = MONUMENT
- NPBCID = NORTHERN PALM BEACH COUNTY IMPROVEMENT DISTRICT
- O.R.B. = OFFICIAL RECORD BOOK
- P.B. = PLAT BOOK
- P.B. Co. = PALM BEACH COUNTY
- PCP = PERMANENT CONTROL POINT
- PG(S). = PAGE(S)
- PRM = PERMANENT REFERENCE MONUMENT
- R. = RADIUS
- R/W = RIGHT OF WAY
- S.F. = SQUARE FEET
- U.E. = UTILITY EASEMENT
- W. = WIDTH

LEGEND:

- = DENOTES SET "PRM" SET 4"x4" CONC. MON. W/ DISK STAMPED "PRM LB 4431"
- = DENOTES FOUND "PRM" FOUND 4"x4" CONC. MON. W/ DISK STAMPED "PRM LB 4431"
- = DENOTES SET "PRM" SET 5/8" IRON ROD W/ METAL CAP STAMPED "PRM LB 4431"
- ⊙ = DENOTES SET "PCP" SET MAG NAIL W/ DISK STAMPED "PCP LB 4431"
- ⊗ = DENOTES SET "PCP" SET 5/8" IRON ROD W/ CAP STAMPED "PCP LB 4431"

FEC RAILROAD

CENTERLINE (DEED BOOK K, PAGE 346) (100' RIGHT-OF-WAY)

EXISTING WESTERLY RAILROAD R/W LINE

EXISTING EASTERLY RAILROAD R/W LINE

STATE ROAD 811 (ALTERNATE A-I-A)

DETAIL SHEET

LIDBERG LAND SURVEYING, INC.

675 West Indiantown Road, Suite 200, Jupiter, Florida 33458 TEL. 561-746-8454

CAD:	K:\JUST \ 014242 \ 122-156 \ 11-0258 \ 11-0258-306 \ 11-0258-306.DGN
REF:	
FLD:	
OFF:	CASASUS
CKD:	D.C.L.
FB:	PG.
JOB:	11-0258-306
DATE:	MARCH 2020
SHEET:	7 OF 7
DWG:	D11-0258PP